

EarthWay[®] EV-N-SPRED

ASSEMBLY and OPERATING INSTRUCTIONS

EarthWay EV-N-SPRED[®]

C22HD & C22HDS

Broadcast Spreader rev. 11-06

PLEASE CALL IF YOU ARE MISSING ANY PARTS, HAVE ANY DIFFICULTY IN ASSEMBLY, OR HAVE ANY QUESTIONS REGARDING THE SAFE OPERATION OF THIS SPREADER. THIS MODEL INCLUDES LIFETIME TECHNICAL SUPPORT SUPPORT HOT LINE: 574-848-7491 or 800-294-0671 EMAIL: support@earthway.com

HELPFUL HINTS:

- ◀ If your spreader does not spread evenly, be sure the **FRONT** on the gear box points to the front of the spreader. The impeller must turn clockwise. Reversing the gearbox will cause the impeller to turn counter clockwise. Clean the impeller after each use as some fertilizer may become stuck on the impeller blades and will cause uneven spreading.
- ◀ Your spreader is designed to be pushed at three miles per hour, which is a brisk walking speed. Slower or faster speeds will change the spread patterns. Wet fertilizer will also change the spread pattern and flow rate. **Clean and dry** your spreader thoroughly after each use. Wash between the shut off plate and bottom of the hopper.
- ◀ Gears are permanently lubricated at the factory. Do not open the gearbox or dirt may enter.
- ◀ When using **Rock Salt** remove the agitator to prevent damage to the gearbox and remove salt from the hopper daily. **Rock Salt** will reconstitute back into a solid block over night with humidity and will damage your spreader.

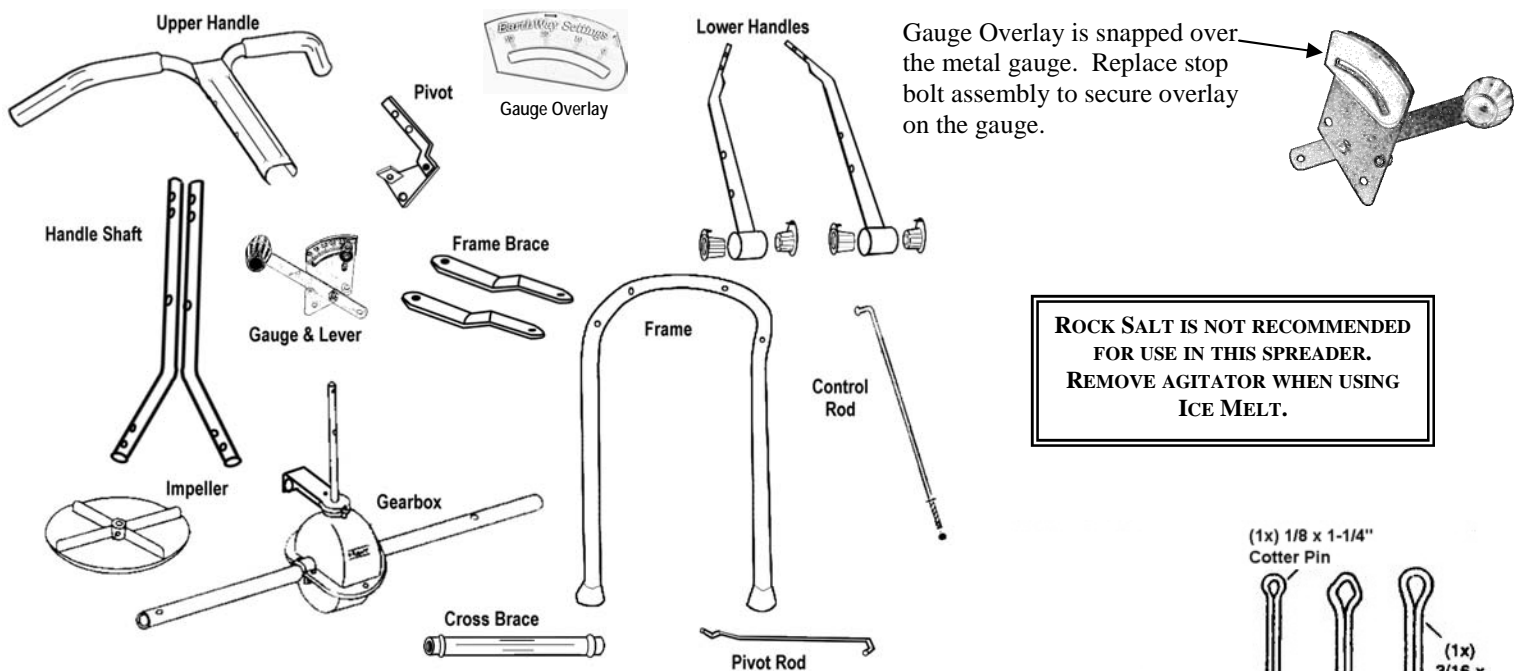

1. Remove and identify all of the loose parts from carton.

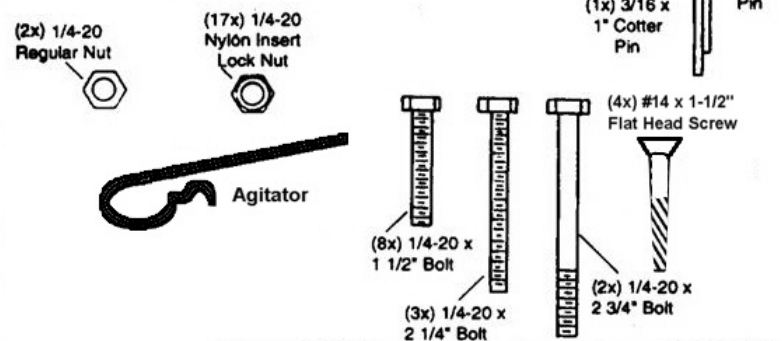
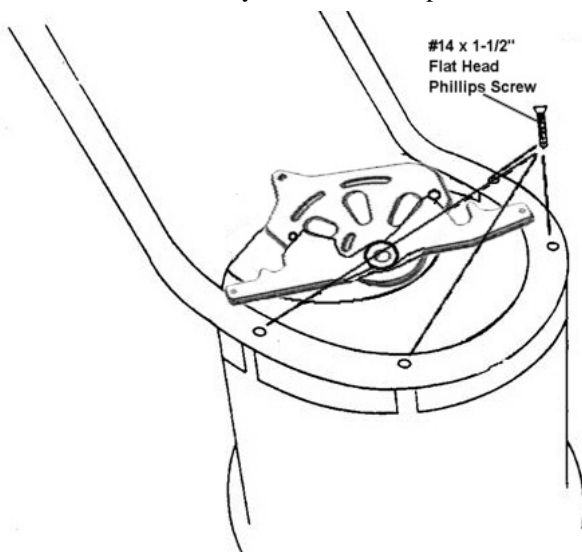

2. Position hopper on side. Install frame using (4) #14x 1-1/2" Flat Head Phillips machine screws.

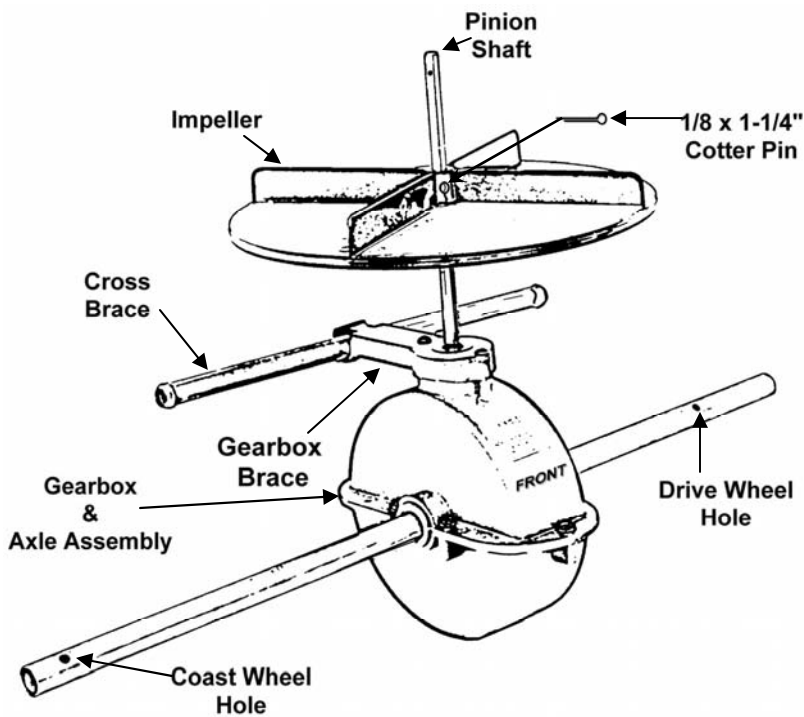

3. Install impeller onto pinion shaft. Insert 1/8" x 1-1/4" cotter pin through impeller then through pinion shaft. Use hole nearest gear box. Spread cotter pin to prevent from falling out. Next, install the Cross Brace through the Gearbox Brace as shown above.

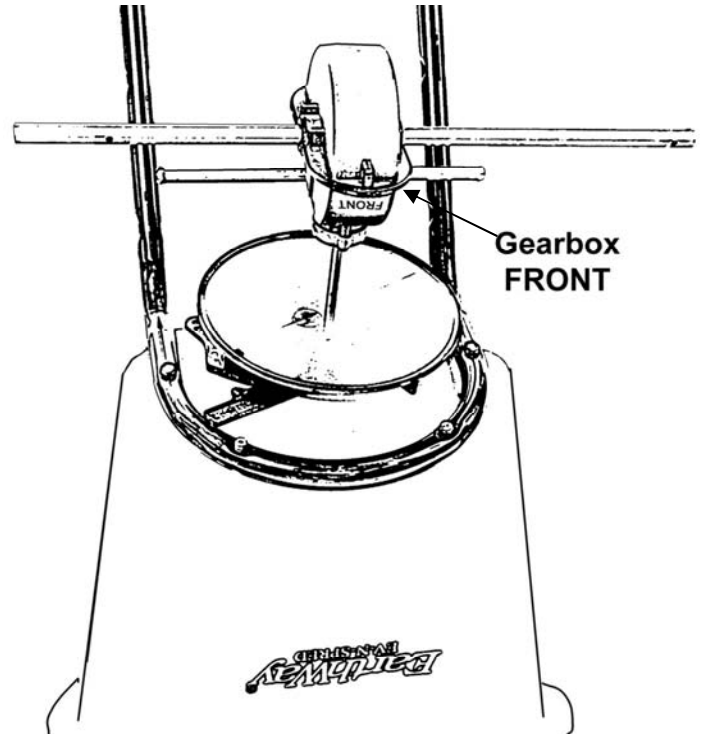

4. Install Gearbox by inserting the pinion shaft into hole in center of hoppers bottom. The word "FRONT" on the gearbox must point to FRONT of the hopper.

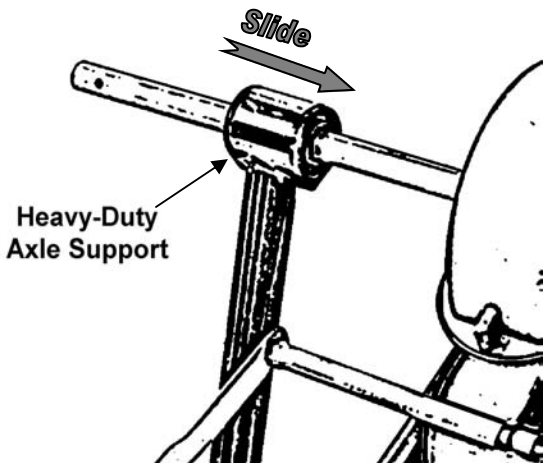

5. Install Lower Handles onto Axle to both sides as shown above. Now insert 1-1/2" bolt through first hole in lower handle, then through frame brace, and finally into the threaded connector in the Cross Brace.

[NOTE: Dimples on frame braces must be facing toward gearbox as shown.]

DO NOT TIGHTEN YET.

Next insert 1-1/2" bolt through other end of frame brace and through second hole in frame install locknut.

DO NOT TIGHTEN YET.

Now insert 2-1/4" bolt through second hole in lower handle and through first hole in frame.

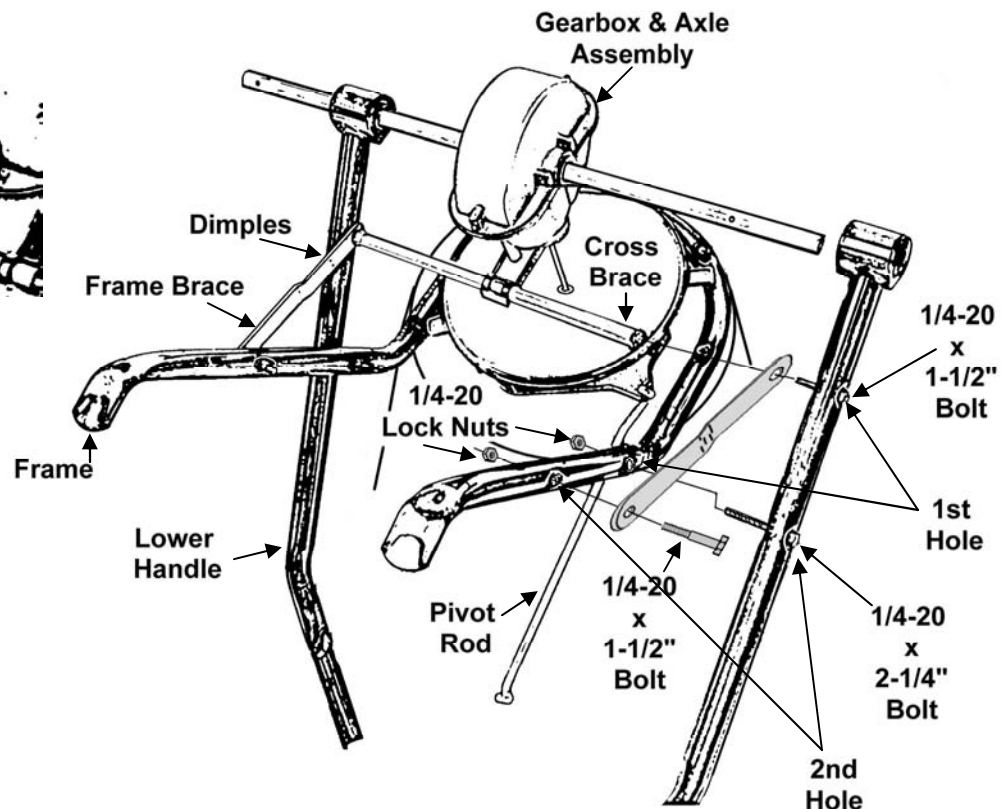

NOW GO BACK AND TIGHTEN ALL NUTS AND BOLTS STARTING WITH FIRST STEP. DO NOT OVER TIGHTEN.

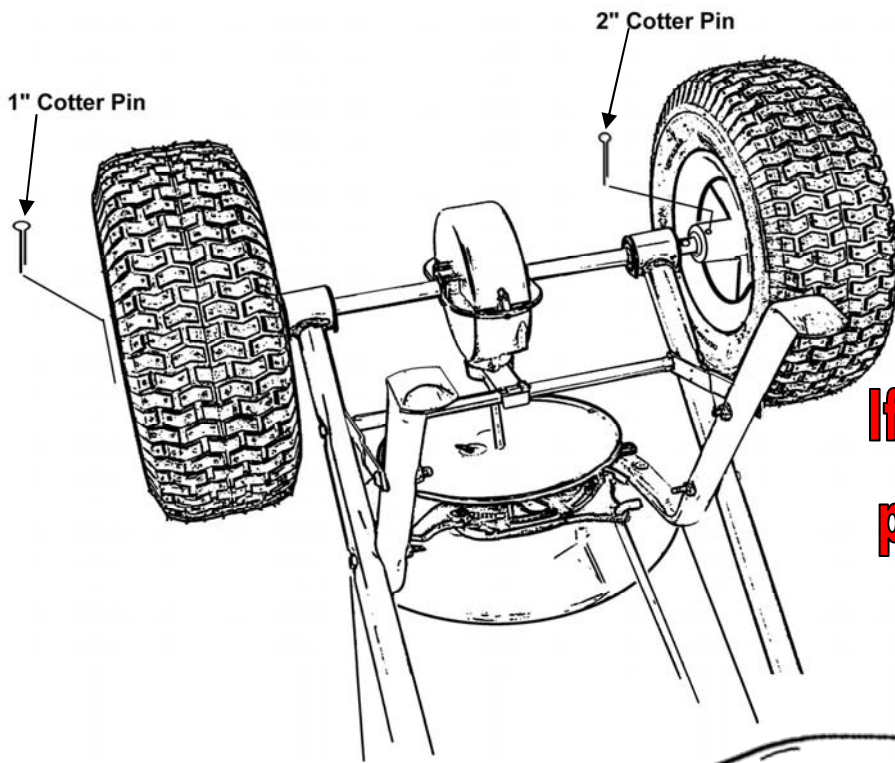

6. Install drive wheel to axle using pin hole nearest to lower handles as shown. Insert 2" cotter pin through wheel and through axle. Bend with pliers to prevent pin from falling out.

NEXT

Install coast wheel to axle using outside pin hole as shown on the left, insert 1" cotter pin through axle [NOTE: not thru the wheel]. Bend with pliers to prevent pin from falling out.

TURN SPREADER UPRIGHT ON TO WHEELS

**If you have any questions
please call 800-294-0671**

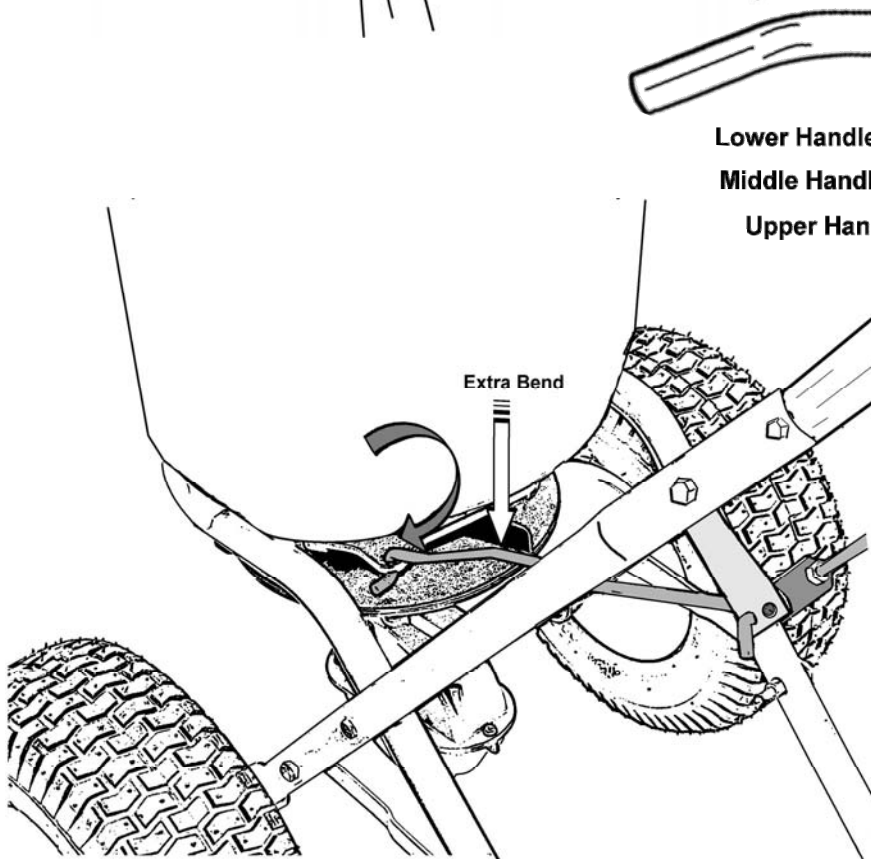

7. NOTE: BEFORE INSTALLING THE GAUGE & LEVER ASSEMBLY AND UPPER HANDLE TO THE HANDLE SHAFT, SELECT THE BEST POSITION FOR THE OPERATOR'S COMFORT. You can select lower, middle, or upper positions for best fit to the operator's height. Insert 2-3/4" bolt through the Gauge, then upper handle and finally through handle shaft. See example to the right.

DO NOT TIGHTEN LOCKNUT YET.

8. Insert pivot rod into shut off plate as shown above. [TIP: Insert rod end with extra bend from the top, then push down & turn to lock in place.]

9. Insert other end of pivot rod into pivot and bracket assembly as shown. [TIP: Insert rod end from the side that has the angle attached to the bracket, then turn to lock in place as shown at the right and above. The correct positioning of the Pivot Bracket has the Angle and Attaching Arm facing away from the gearbox.]

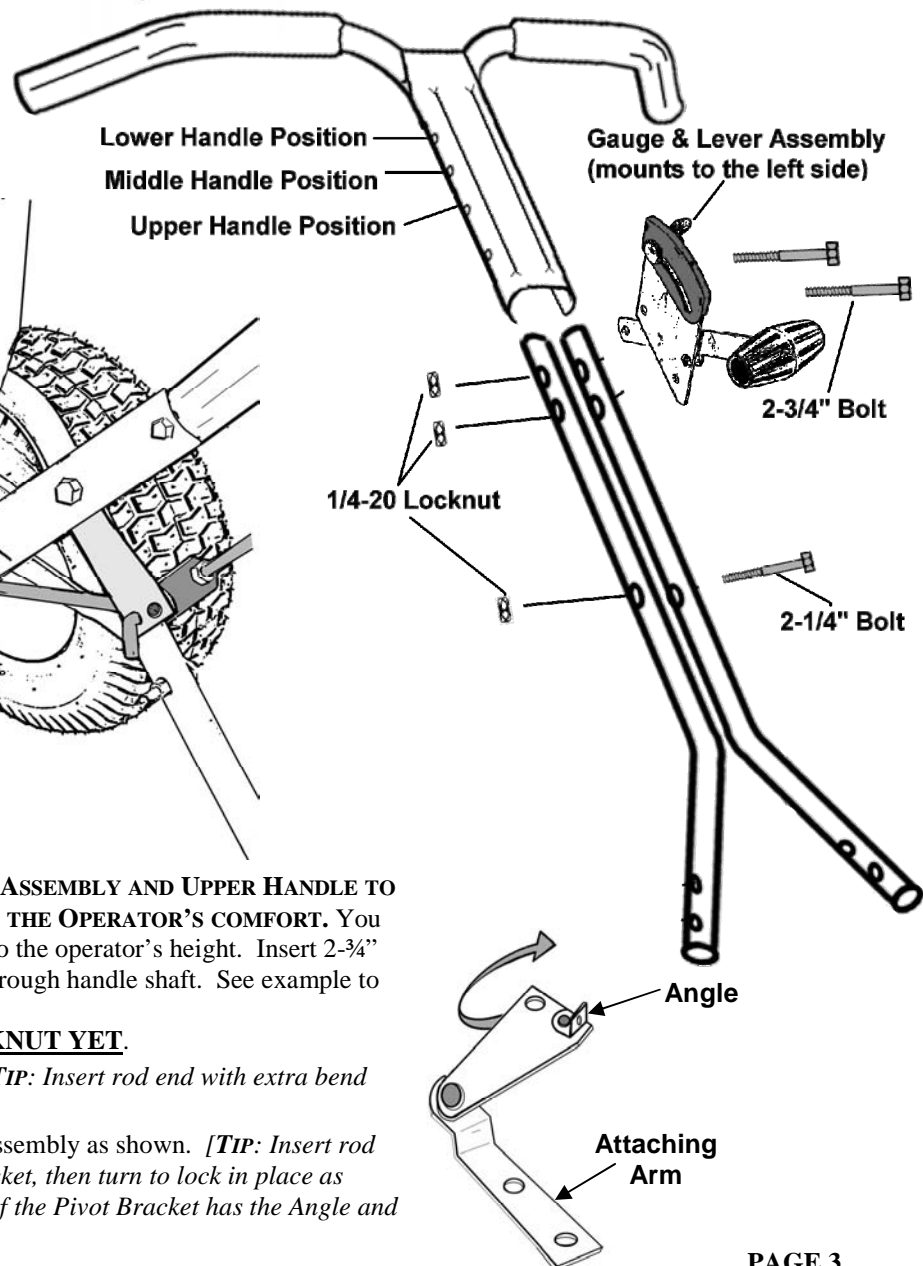

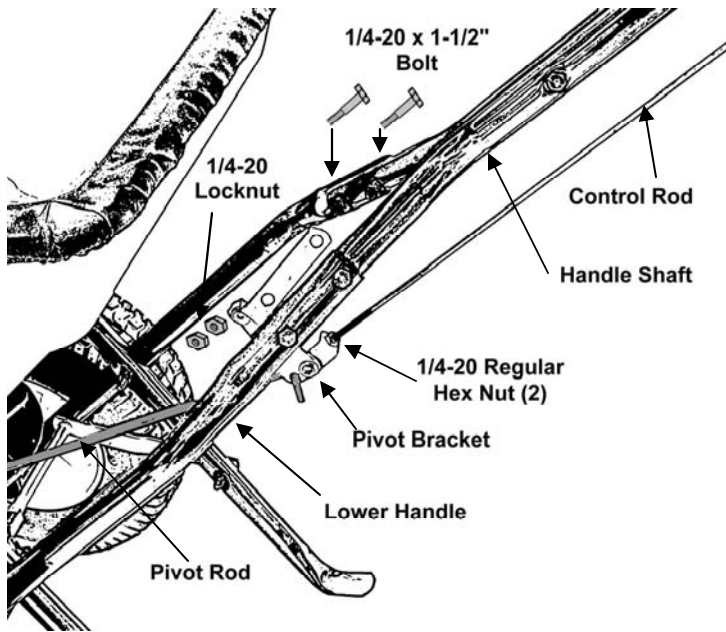

10. Install handle shaft to lower handles and pivot & bracket assembly as shown. Using (4) 1 1/2" bolts and (4) locknuts. [TIP: Attach right side first, then attach left (Pivot Bracket) side]

TIGHTEN BOLTS AND NUTS NOW.

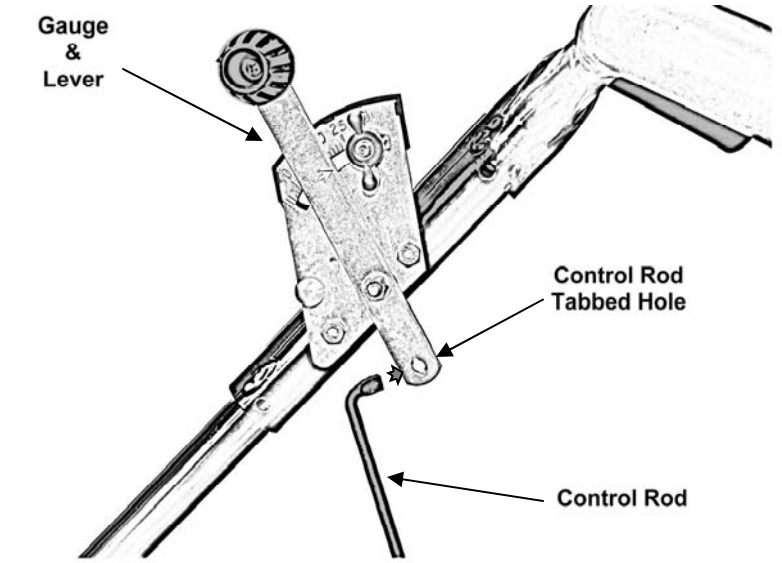
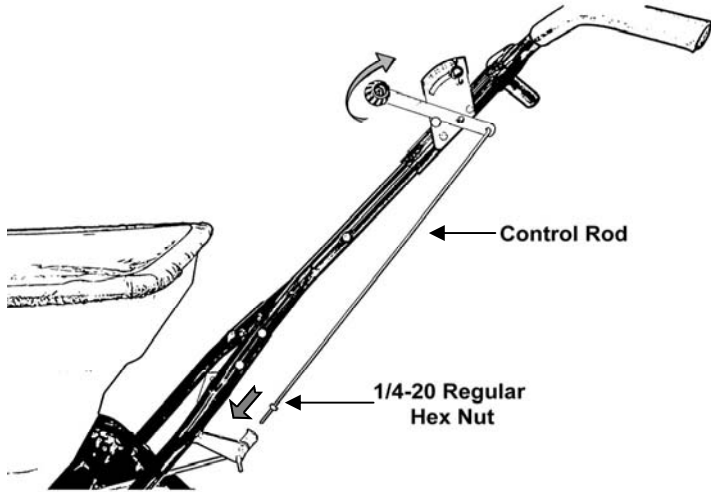

11. Install flattened end of control rod in to lever on gauge into Control Rod Tabbed hole as shown. Turn to lock in place.

NEXT:

Install (1) 1/4-20 Regular Nut [not a locknut] on to Control Rod and thread halfway as shown to the left.

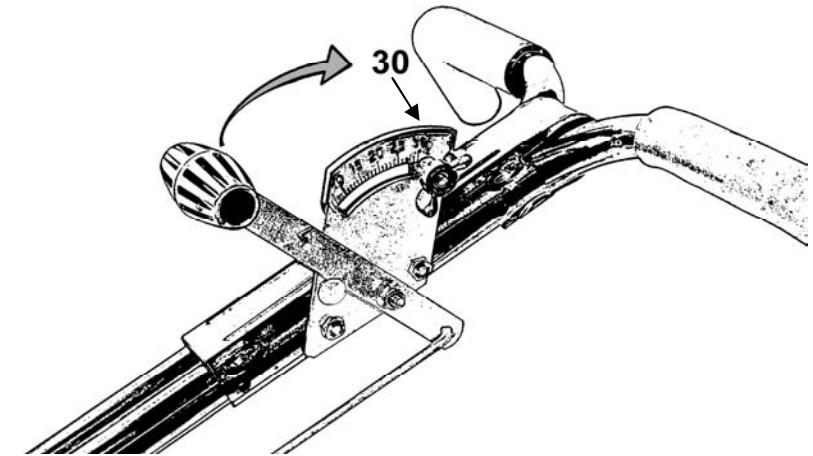

12. Next push lever forward to setting "0". Align control rod with hole in pivot bracket, pull lever backward to insert control rod through hole in pivot bracket. [TIP: If the lever does not move easily, loosen slightly to make this step easier] Now install 1/4-20 regular nut on to Control rod.

DO NOT TIGHTEN NUTS YET.

13. Pull lever back to setting "30" as shown. Next push pivot & bracket forward so that the shut off plate in the hopper is in the full open position. [NOTE: THE SETTING OF "30" ON THE GAUGE & LEVER ASSEMBLY MUST OPEN THE SHUT-OFF COMPLETELY FOR PROPER CALIBRATION.] Now tighten the nuts against the pivot bracket to prevent change in calibration. Test by opening and closing the Gauge & Lever a few times to ensure an accurate calibration.

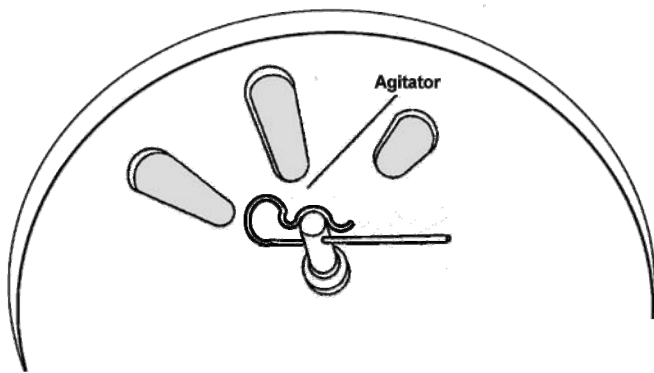

14. Insert Agitator to pinion shaft on inside of hopper.

NOTE: Position of flat side of agitator. This pin should be installed as shown.

15. Tension on the flow control lever may be adjusted by tightening or loosening the tension nut as shown on the right.

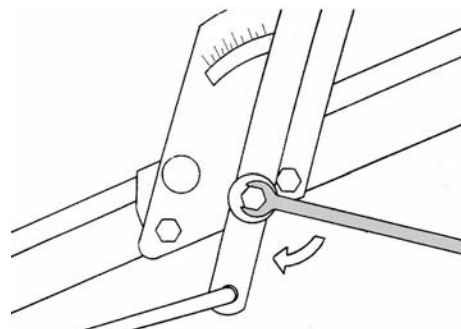

16. For normal operation both doors should be fully opened. To reduce flow to the left side, partially or completely close the door over the rear (**LARGE**) hole. To reduce flow to the right side, partially or completely close the door over the front (**SMALL**) hole. Close both doors for a narrow center spread pattern.

WARNING: If the optional side deflector is being used in the down position, the plate over the rear (**LARGE**) hole **MUST BE CLOSED** or an over application of material will occur. For additional information on this feature, please visit www.earthway.com/pdf%20files/Spredguide.PDF or look for *Spread Guide* under the Manuals section on www.earthway.com



The New EV-N-SPRED®

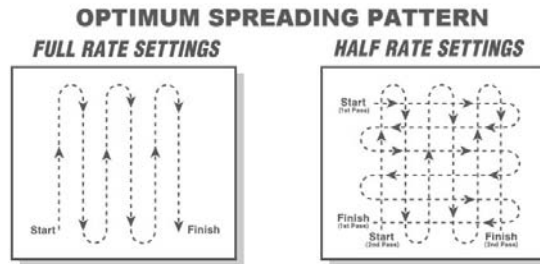

The settings furnished on the Setting Matrix are intended as a guide only. Variations in physical characteristics of material applied, walking speed, and roughness of ground surface may require slightly different spreader settings. Due to these conditions, *EarthWay* Products, Inc. makes no warranty as to the uniformity of coverage actually obtained from the settings listed.

WARRANTY

EarthWay guarantees this product to be free of defects in original workmanship and materials for a period of 90-days from sale to the original user. If any defect develops during this period *EarthWay* will repair or replace this product at no charge provided the defect is not the result of mishandling or tampering and that this product is received at the factory with shipping charges prepaid. For quicker service you may call *EarthWay* at (574)848-7491 & 800-294-0671, or email at sales@earthway.com and describe the nature of the defect and we will send repair parts to you.

Due to the corrosive nature of most fertilizers and ice melters, *EarthWay* Products, Inc. makes **NO WARRANTY** or **GUARANTEE** against corrosion failure. Clean and dry your spreader thoroughly after each use. Warranty covers parts only, not any labor charges to replace or repair your spreader.

DO NOT RETURN TO DEALER

EARTHWAY PRODUCTS, INC.
1009 Maple Street
P.O. Box 547
Bristol, IN 46507

FOR YOUR RECORDS

OPERATING INSTRUCTIONS

Before filling hopper, become familiar with the operation of this spreader.

- * Obtain proper setting for material to be used from the enclosed **SETTING MATRIX** included with this spreader, or from our web site under the **MANUALS SECTION**.
- * Move stop bolt on rate gauge assembly to the proper setting.
- * While pushing spreader forward, pull control lever back to stop bolt.
- * To stop, push lever forward to close flow holes before you stop moving.
- * When finished, empty any remaining material from hopper.
- * Thoroughly wash spreader and allow to dry before storing. No oiling is necessary.
- * Remove agitator when using Rock Salt to prevent damage to the gearbox.

HOW TO ORDER SPARE PARTS

All spare parts listed may be ordered direct from **EARTHWAY PRODUCTS, INC.** Be sure to give the following information when ordering.

- 1. Model Number**
- 2. Part Number**
- 3. Part Description**

Call (574) 848-7491 or email (sales@earthway.com) for current prices.

Date Purchased

Store Name

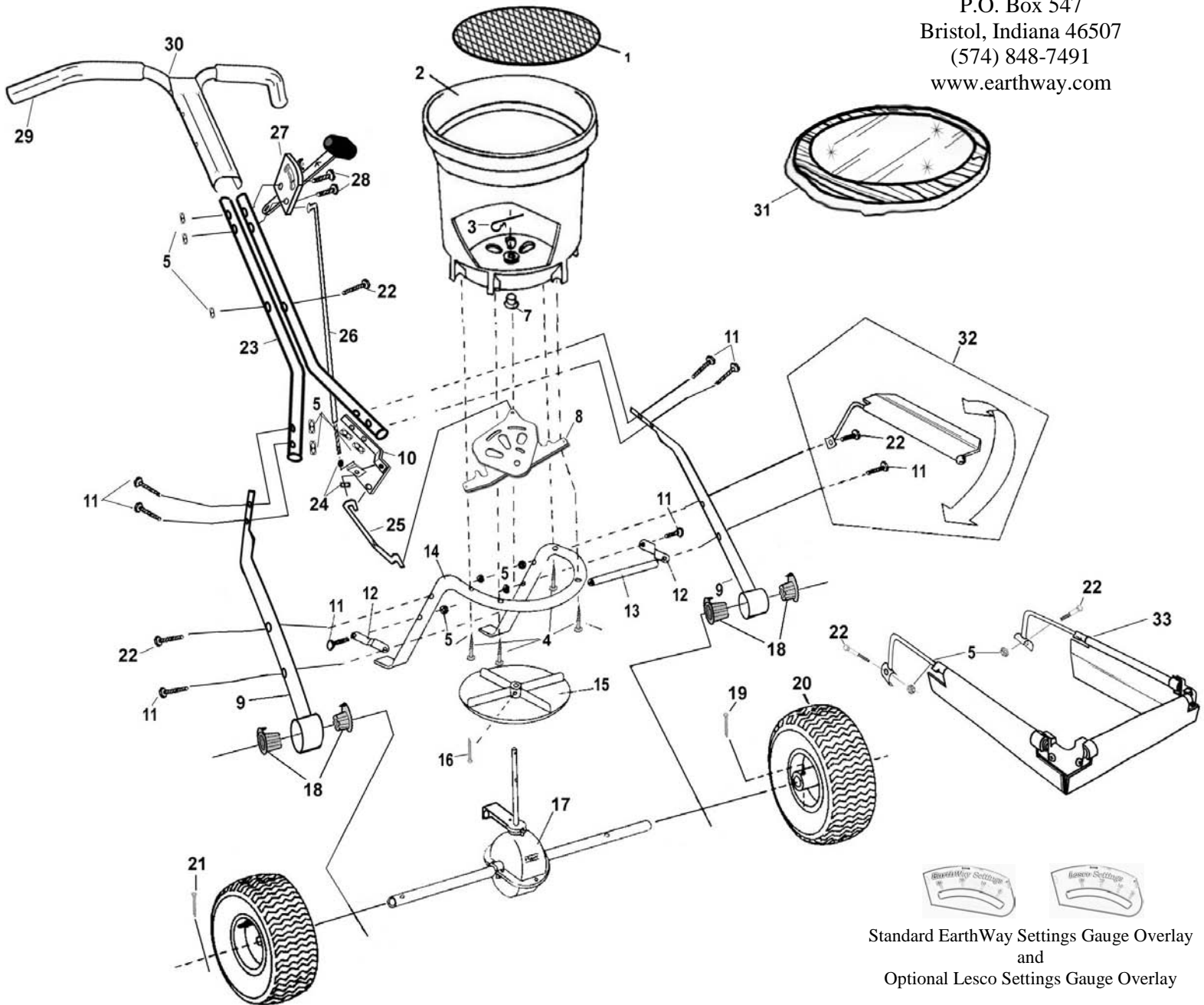

C22 Series Broadcast Spreaders

Key #	Part #	Description	Key #	Part #	Description	Key #	Part #	Description
1	40002	Screen	14	24100	Frame C22HDS	25	44251	Pivot Rod (double bend)
2	60152	Hopper Assembly, Includes Key #7 & 8	14	25102	Frame C22HD	26	42256	Control Rod
3	33117	Agitator	15	12109	Impeller	27	60298	Gauge & Lever Assembly
4	N/A	*#14 X 1 1/2" Flat Head Screw	16	N/A	*1/8" X 1-1/4" Cotter Pin	28	N/A	*1/4-20 X 2-3/4" Bolt
5	N/A	*1/4-20 NYLON Locknut	17	60333	Gear Box & Axle Assembly	29	12273	Handle Grip
7	12220	Hopper Bushing	18	12352	New Axle Bearing	30	60069	Upper Handle Assembly C22HD W/Grip
8	12278	New Pro Shut-Off Plate	19	N/A	*3/16" X 2" Cotter Pin	30	60070	Upper Handle Assembly C22HDS W/Grip
9	24202	Lower Handle C22HDS Stainless	20	19117	Drive Wheel /Coast Wheel	31	77001	Optional Heavy Duty Rain Cover
9	25202	Lower Handle C22HD Painted	21	N/A	*3/16" X 1" Cotter Pin	32	60043R	Optional Heavy Duty Rain Cover & Side Deflector Kit
10	60299	Pivot & Bracket Assembly	22	N/A	*1/4-20 X 2-1/4" Bolt	33	60166R	Optional Salt Deflector
11	N/A	*1/4-20 X 1-1/2" Bolt	23	24301	Handle Shaft C22HDS			
12	42237	Frame Brace	23	25301	Handle Shaft C22HD			
13	24704	Cross Brace	24	N/A	*1/4-20 Hex Nut			

N/A * Source locally, can be found in most hardware stores